



PANORAMIC HM



PERFORMANCE AND FEATURES	P50.18HM	P65.14HM	P120.10HM
PERFORMANCE			
Total unladen weight (kg)	16250	15800	16200
Maximum capacity (kg)	5000	6500	12000
Lifting height (m)	17,9	13,9	9,8
Maximum reach (m)	13	8,8	5,3
Maximum operating height (m)	12,9	10,2	6,9
Maximum operating reach (m)	3,8	3	1,3
Capacity at maximum height (kg)	3000	4000	7000
Capacity at maximum reach (kg)	500	1600	2900
Lateral boom movement (mm)	± 440	± 375	± 185
Tilting correction (%)	± 8	± 8	± 8
Boom sections	4	3	2
POWERTRAIN			
Turbo motor	FPT NEF45	FPT NEF45	FPT NEF45
Displacement/cylinders	4500/4	4500/4	4500/4
Engine Power (kW/HP)	125/170	125/170	125/170
Anti-pollution technology	STAGE V - SCR +DPF +DOC	STAGE V - SCR + DPF+DOC	STAGE V - SCR + DPF+DOC
Reversible fan	-	-	-
Maximum speed (km/h)	40	40	40
Fuel tank (l)	150	150	150
AdBlue tank (l)	43	43	43
Hydrostatic transmission	CVTronic	CVTronic	CVTronic
EPD	Top	Top	Top
Auto-revving joystick	●	●	●
Axles - Reducers	Axial, Epicyclic	Axial, Epicyclic	Axial, Epicyclic
Machine brakes	Wet disc	Wet disc	Wet disc
Automatic parking brake	●	●	●
HYDRAULIC			
Hydraulic pump	LS + FS	LS + FS	LS + FS
Flow rate/pressure (l/min – bar)	158- 210	158- 210	158- 210
Hydraulic tank	149	149	149
Hydraulic outlet at the top of the boom	●	●	●
Rear hydraulic outlets	○	○	○
CAB			
Cab configuration	Premium	Premium	Premium
ASCS Adaptive Stability Control System	Full	Full	Full
FOPS LIV II cab	●	●	●
ROPS cab	●	●	●
Cab commands	Electronic joystick	Electronic joystick	Electronic joystick
Tilting Cab	-	-	-
Reverse shuttle	Dual reverse	Dual reverse	Dual reverse
CONFIGURATION			
Cab suspension	-	-	-
Boom suspension	-	-	-
Suspension on axles	-	-	-
Work headlights on cab	●	●	●
Sun blind	●	●	●
Tac-lock	●	●	●
Provision for a platform	○	-	-
Two floating forks	●	●	●
Inching-Control	●	●	●
Four-wheel drive	●	●	●
Four-wheel steering	●	●	●
Three steering modes	●	●	●
Standard tyres	17.5-25"	17.5-25"	17.5-25"
Optional tyres	-	-	-
Stabilisers	-	-	-
Turret rotation	-	-	-
Type approval as an agricultural tractor	-	-	-
Approval with PNEUMATIC braking	-	-	-
Approval with HYDRAULIC braking	-	-	-
PTO	-	-	-
3-point linkage	-	-	-

- Not Available. ● standard. ○ optional.

LOAD CHARTS

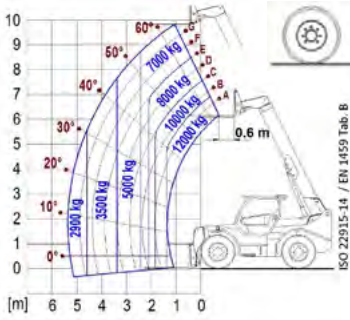

P120.10HM

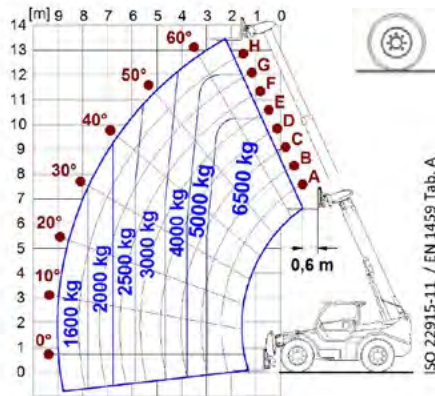

P65.14HM

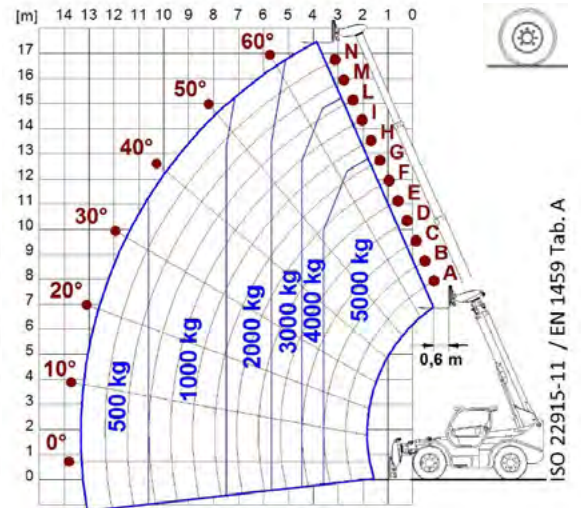

P50.18HM

DIMENSIONS

	P50.18HM	P65.14HM	P120.10HM
A (mm)	6180	5910	5720
B (mm)	1605	1335	1145
C (mm)	3240	3240	3240
D (mm)	1335	1335	1335
E (mm)	5235	5235	5210
F (mm)	450	450	450
H (mm)	2520	2520	2520
M (mm)	1010	1010	1010
P (mm)	2850	2850	2850
R (mm)	4300	4300	4300
S (mm)	5480	5400	5700
Z (mm)	850	850	635/1170

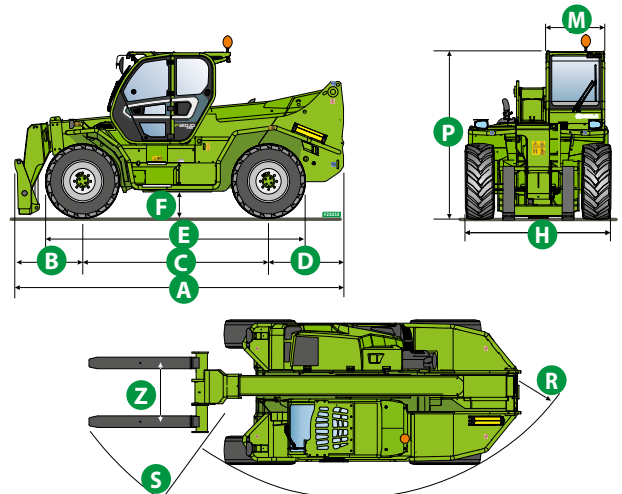



MERLO S.P.A.

Via Nazionale, 9
12010 S. Defendente di Cervasca
(Cuneo) Italia

Tel. +39 0171 614111

Fax +39 0171 684101

info@merlo.com

www.merlo.com

Your Merlo dealer

DS_PANHM_0521_ENG